

# TURBOSTART

# HYDRODYNAMIC COUPLINGS

from 0.37 to 1470 Kw



# TECHNICAL CATALOGUE

## TURBOSTART

### HYDRODYNAMIC COUPLINGS

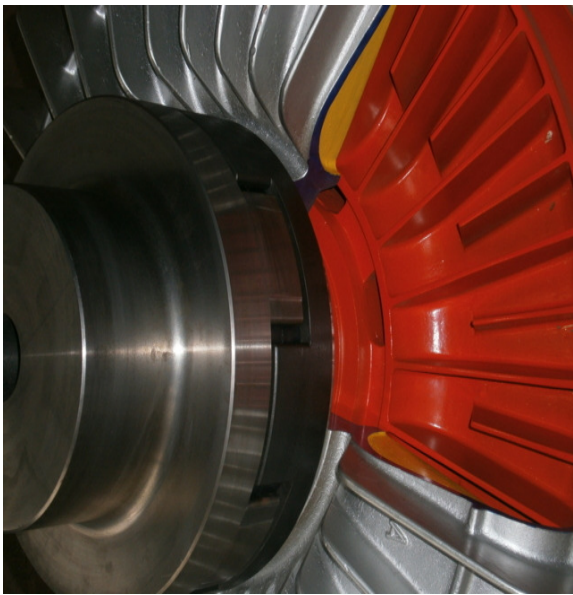

**New Turbostart s.r.l.** was born in 1958, its corporate purpose is the production and sale of mechanical and hydraulic drives; the company has always been renowned for their new products reliability and professional service offered to clientele. It is a compact structure, efficient and always ready to solve the most varied problems of customers, succeeding in realizing even personalized products, guaranteeing, at the same time, rapidity and prompt deliveries. Over the years, it has always followed quality objectives, **officially recognized on several occasions all over the world.**

New Turbostart is in **continual development, both in Italy and abroad** (all continents) where it is selling hydrodynamic and hydromechanic couplings without slip at continuous running and 100% efficiency, couplings in cast iron for mines applications for powers ranging from 0,37 to 2.200 Kw, both for in line and pulley assembly, and also disk brake, drum brake, and all metal flexible couplings.

The administration and commercial offices are placed in Milan – Segrate, while production factory is located in Borgo Ticino – Novara, which is owned by New Turbostart and it covers 7.000 sq.m.

The factory is equipped with numerically controlled operating machines; processing of all particulars are carried out inside, as well as assembly and testing, whereas castings are made by skilled foundries in primary aluminium alloy

New Turbostart is certified, according to **UNI EN ISO 9001 – 2008** regulation, and it can supply couplings in according ATEX Certification.



1. Index
2. The Hydrodynamic Coupling - Principle of operation
3. The Hydrodynamic Coupling
4. The Hydrodynamic Coupling - Outer line
5. Production program in line version
6. Production program in line version
7. Production program for pulley version
8. Performance calculation
9. Selection graph
10. In line version type LS - LR/S
11. In line version type L-MU - LR/MU
12. In line version type LE - LR/E
13. In line version type LE version 112 LRE
14. In line version with brake drum type LE-FF - LRE- FF
15. In line version with brake disk type LE-DF - LRE- DF
16. In line version for half gear couplings type CF - CFR
17. In line version for all metal flexible coupling type CF-LS    CF-LS-R
18. Pulley version type PF - PFR (flanged pulley)
19. Pulley version type PT - PTR ( hollowed pulley)
20. Pulley version type PI - PCS (Incorporated pulley)
21. Pulley version type PC - PCR ( keyed pulley)
22. Partial Draining Device (R)
23. Protection Device
24. Instructions for installation and maintenance
25. Controls
26. Weights

The Hydrodynamic Coupling is a device of transmission of primary importance and has a large field of application. It is simultaneously a gradual starter and a stress eliminator and it is able to create in every moment and automatically an equilibrium between the motor and the transmission of the operating machine; therefore it eliminates every dangerous and unexpected overload and protects the motor and the transmissions as well.

## PRINCIPLE OF OPERATION

The Turbostart Hydrodynamic Coupling consists of two impellers with symmetric vanes, a primary (pump) and a secondary turbine. The primary impeller driven by a motor sends a continuous flow of oil against the second impeller, transmitting therefore power to the other device.

Since the two impellers are opposite and have symmetric vanes, the result is that the Hydrodynamic Coupling has a perfect reversible function; also it is able to work horizontally, vertically or inclined (for sizes 18 - 19 - 110 P it's important to specify). The output speed of the standard Hydrodynamic Coupling is always lower than the input speed; the difference between the two speeds is commonly called "slip" and it is measured in percentage (%).

Under a constant torque the slip is maintained constant but if the output load increases, the secondary impeller (turbine) will slow down.

As a consequence there is an increase of liquid velocity into the fluid coupling and resulting in an increase of kinetic energy.

This increase of energy, pressing on the secondary impeller (turbine), balances the increased output load.

If this new output load is maintained constant and the motor is capable of supplying the equivalent power, a new equilibrium is established, characterised by a greater constant slip. On the contrary, at a decreasing output load, everything described above is inverted and the slip diminishes.

According to the slip we can determine the efficiency of the coupling and the value of power that is transformed into heat.

An accurate selection based on the effective power absorbed by the driven equipment determines the selection of the Hydrodynamic Coupling able to dissipate by natural ventilation the heat produced.

The Hydrodynamic Coupling with standard seals can normally withstand a maximum temperature of approximately 100° C and, with special seals, approximately 200° C.

## ADVANTAGES

The Hydrodynamic Coupling, inserted into a transmission for starting up a high inertia machine controller by an asynchronous electric motor with Direct on Line Starting has the following advantages:

- **Eliminates the rigidity** of the mechanical transmissions and guarantees the flexibility of the Hydraulic transmission withstanding all the shocks, torsional vibrations and unexpected overloads, and protects the motor and driving machine.
- **Reduces peak current** during start-up. The electric motor rapidly reaches the operating speeds with low peak current.
- **Permits smaller motor sizes** according to the power demand of the driven machine.
- **Permits a high stop start** duty cycle even under load, sudden changes of direction and plug (reverse) braking.
- **Distributes the load in installations** where two or more motors are installed. The Hydrodynamic Coupling allows every motor to reach its own operating speed, automatically distributing load demand.

## EXAMINATION OF THE BEHAVIOUR OF THE ELECTRIC MOTOR AND THE HYDRODYNAMIC COUPLING DURING THE START-UP

To fully realize the above mentioned advantages, it is necessary to select the correct hydrodynamic coupling. Let us consider the behaviour of both the motor and hydrodynamic coupling when the two items are working together, from the moment of the start to full speed.

Examining the diagram Torque (C) vs Speed (v)

Fig. 1 on which the curves:

M - torque curve of a direct start (DOL) asynchronous electric motor.

| - Current vs Speed (v).

Following the curve M during starting (when  $v=0$ ) we notice that the available torque  $C_a$  is approximately 1.5 times the rated torque  $C_n$  on DOL starting, and approximately 0.6 times  $C_n$  on Star Delta Starting ( $C_{st}$ ).

Normally the motor operates at speed  $n_1$  where the rated torque  $C_n$  is equal to the working torque.

It should be noted that the motor produces maximum torque  $C_M$  of 2.5 times the rated torque  $C_n$  at the speed  $n_M$  (90% of rated speed).

Following curve "I" we note that the current at start  $I_a$  is 5-6 times the nominal rated current.

At this stage the motor temperature is rather high.

At speed  $n_M$  the current  $I_M$  is about 3 times the rated current  $I_N$  and the temperature of the motor is noticeably reduced; also the elevated speed of the motor facilitates its own cooling.

Therefore, during startup the motor must reach speed  $n_M$  as quickly as possible in order to avoid overheating, and to deliver maximum available torque to the driven machine.

If there is an exceeding torque  $C_e$ , comparatively low, and no hydraulic coupling is used, the duty cycle will be quite slow, and this could result in damage being done to the motor, unless the motor has been adequately oversized.

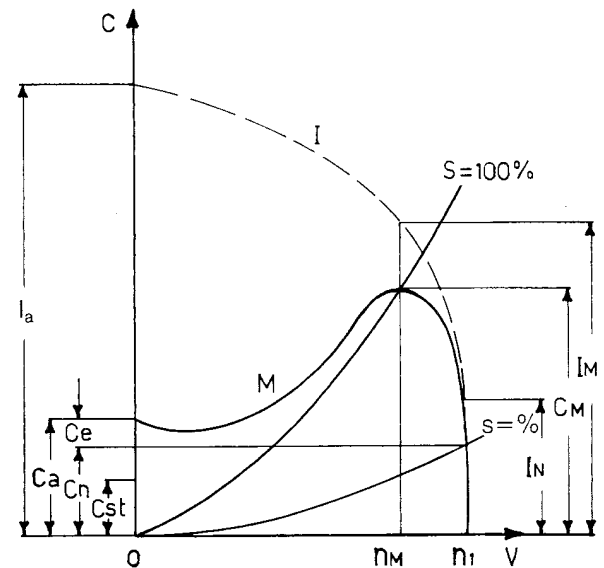

Fig. 1

#### VARIATION OF START CONDITIONS UTILISING THE HYDRODYNAMIC COUPLING

Let us consider a coupling having a slip  $S = 100\%$  crossing the curve  $M$  at the point nearest to the maximum torque (fig. 1).

Since a speed  $v = 0$  the coupling transmits no torque, the electric motor has all torque  $C_a$  available for the rotor acceleration.

During the acceleration the oil moved by the pump element of the hydrodynamic coupling, gets in greater quantity into the circuit, acting more and more on the turbine element connected to the driven machine. As soon as the torque produced by the coupling overcomes the resisting torque, the driven machine starts moving.

At this stage the torque available for the acceleration of the driven machine is  $C_M - C_n$  therefore of higher value of torque  $C_n$ , which is the starting torque available if no hydraulic coupling is used.

It is important to note that the availability of the high accelerating torque is obtained at a current  $I_M$  which is approximately half of the value of the current  $I_a$ , corresponding to the acceleration torque  $C_a$  and the heating of the electric motor is reduced.

As the oil enters the circuit, the difference of speed between the motor and the driven machine diminishes, until an equilibrium is reached between the dragging torque and the resisting torque when the motor reaches its operating speed  $n_1$ .

Then the coupling will work at normal slip  $s$ .

#### THE BEST USE OF MAX MOTOR TORQUE

If the curve of motor torque  $M$  meets the curve of coupling torque  $S$  before the point of max value, it means that the selected coupling is overdimensioned, or there is too much oil inside. Under this condition the rotor has difficulty to accelerate and the hydrodynamic coupling rotates without being able to accelerate the driven machine.

To obviate the inconvenient it is necessary to drain some oil to get a lower slip curve of the hydrodynamic coupling.

Instead, if the curve meets after the point of maximum torque value, it means that the selected coupling is underdimensioned.

It is to keep in mind that the slip of a coupling-filled with a special quality of oil- is a function of the rotating speed, of the resisting torque and of the quantity of oil.

Moreover, if a coupling is requested to operate at different speeds, at equal slip the power and torque transmitted are directly proportional to the cube and square of the requested speeds.

The standard Turbostart Hydrodynamic Coupling can be fitted with a partial oil drainage device, allowing the best use of the maximum motor torque (page 20).

#### USE OF THE HYDRODYNAMIC COUPLING WITH DIESEL ENGINE

The diesel engine has an unstable torque curve and a minimum operating speed below which the engine stalls.

When the stall is caused by overloads, the use of the hydrodynamic coupling eliminates the problem and offers the following advantages.

- **Stabilizes the operation of the engine.** Considering the curve  $M'$  (fig. 2) obtained with a partial supply, we reach a point of equilibrium  $P_4$  when the engine output torque at a speed of  $V_1$ , is equal to the resistive torque transmitted by the hydrodynamic coupling with a slip  $s = \%$ .

At increasing of resistive torque the point of equilibrium is transferred to  $P_3$ , at an engine speed  $V_3$  .and the coupling gradually reaches a 100 % slip. At this stage the governor of the diesel engine increases the speed to  $V_2$ , and the torque to a new point of equilibrium  $C_1$ , is obtained with an output torque supplied by the coupling with a slip of 5 % . These variations are controlled by the hydraulic coupling, which maintains the engine very stable.

- **Facilitates the starting of the engine.** On starting and at low input speed, the hydrodynamic coupling does not oppose to the engine which is free to reach the rated speed. When it is inserted between the engine and a mechanical clutch, noticeably it reduces clutch wear.

- **Prevents the engine stall.** When the driven torque, is higher than the supplied torque the slip of the coupling goes to 100% maintaining the engine a speed higher than the stall speed.

Obviously at this condition the driven machine should be disengaged to avoid build up of temperature into the hydrodynamic coupling

- **Absorbes torsional vibrations.** This feature is very important when controlling machines operating at frequent load variations.

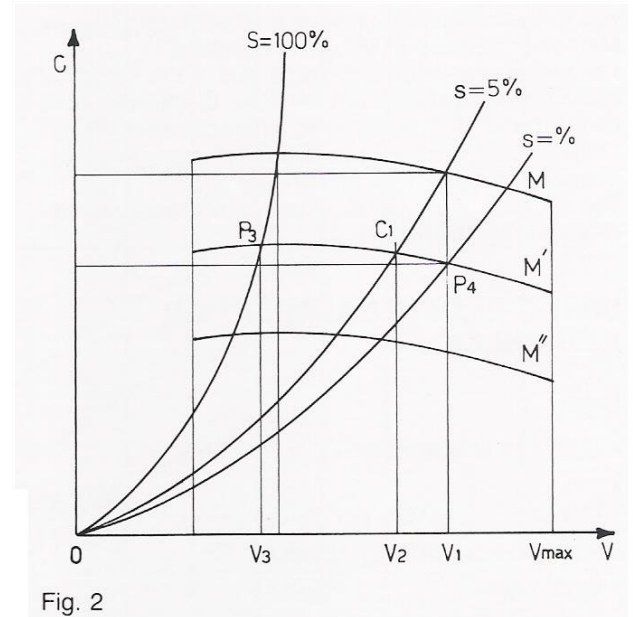
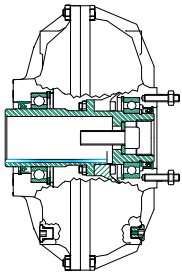
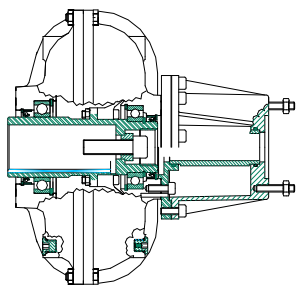

Fig. 2

## THE TURBOSTART COUPLING : OUTER LINE



Models: 155-190-220-240N-275N-400  
155R-190R-220R-240NR-275NR-400R



Models: 355-445-19S-110S  
355R-445R-19SR-110SR

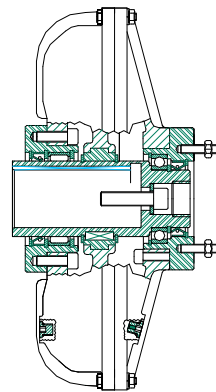

Models: 18-19-110-18R-19R-110R

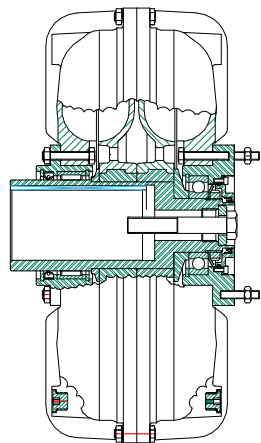

Models: 112-112R

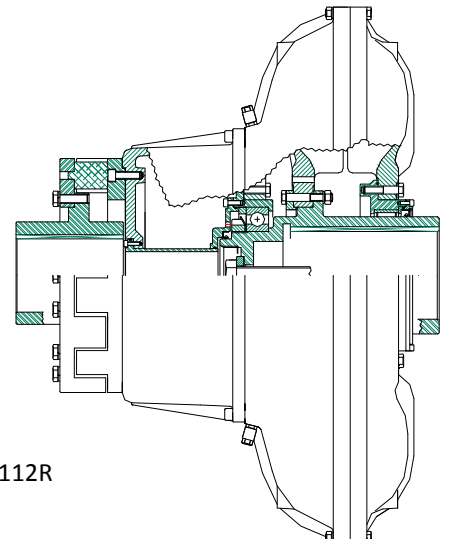
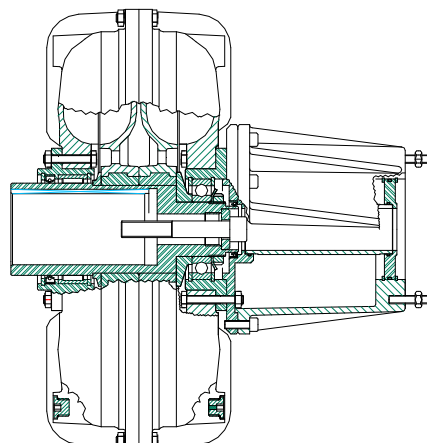

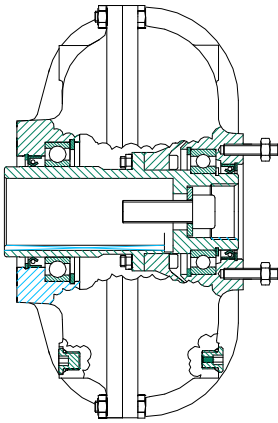

**L/S** With stud bolts

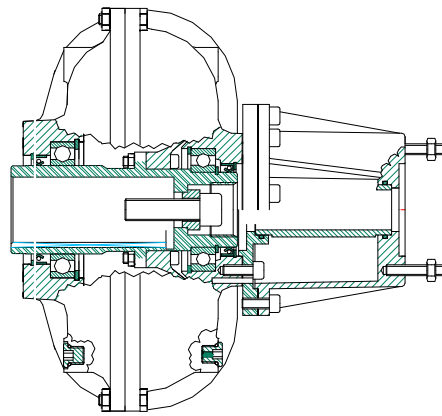

**LS/R** With stud bolts  
and partial draining device (R)

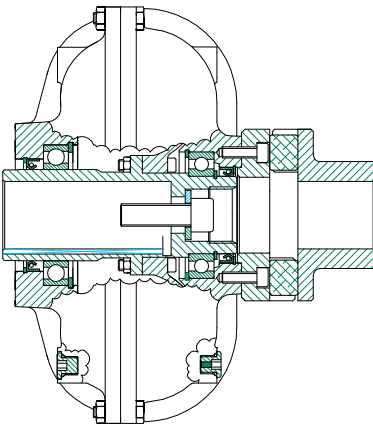

**L/E:** With flexible coupling

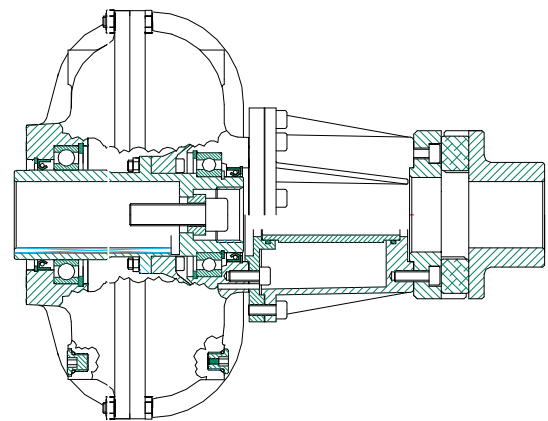

**LR/E:** With flexible coupling  
and partial draining device (R)

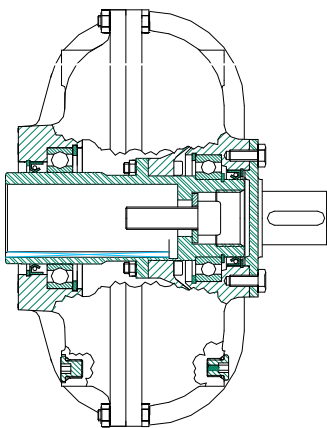

**L/MU:** With stub shaft

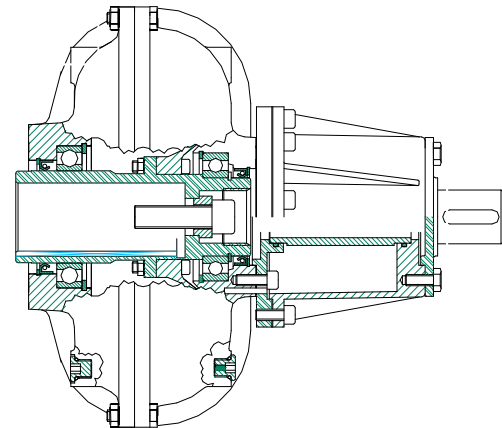

**LR/MU:** With stub shaft  
and partial draining device (R)

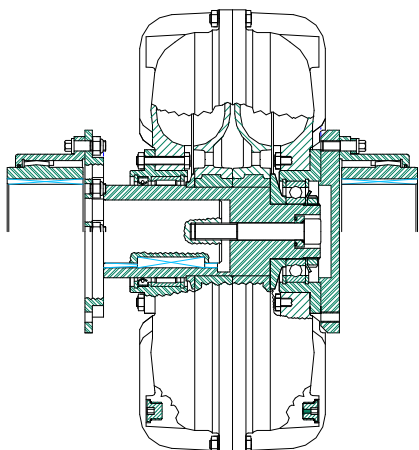

**CF:** With flanges for half gear couplings

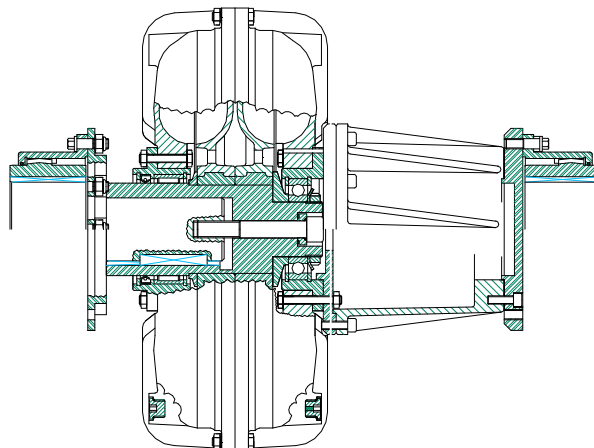

**CF/R:** With flanges for half gear couplings and partial draining device (R)

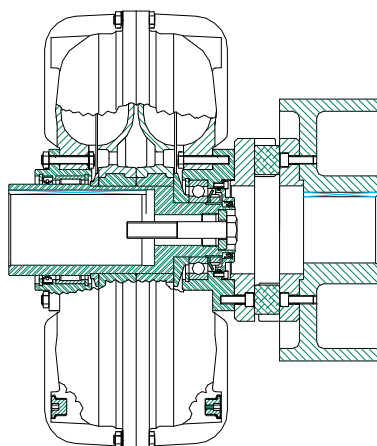

**LE/FF:** With flexible coupling and brake drum

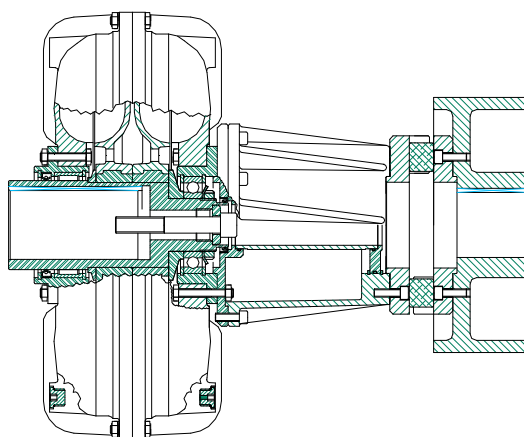

**LR/E FF:** With flexible coupling and brake drum complete with partial draining device (R)

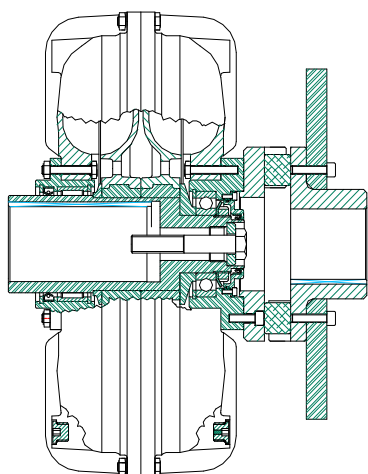

**LE/DF:** With flexible coupling and brake disk

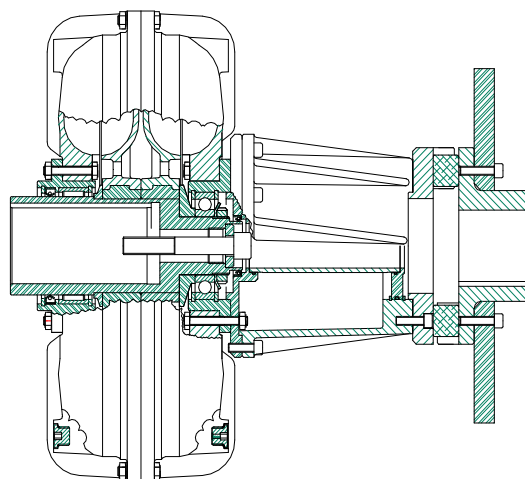

**LR/E DF:** With flexible coupling and brake disk complete with partial draining device (R)



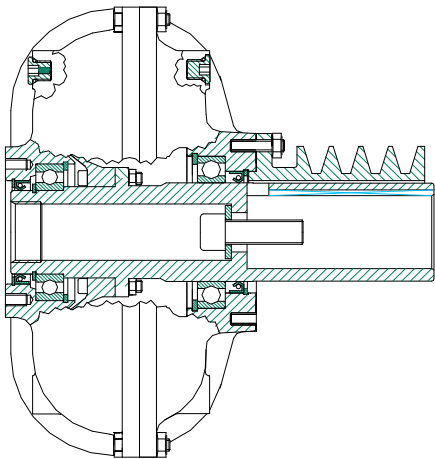

**PF:** Version for flanged pulley

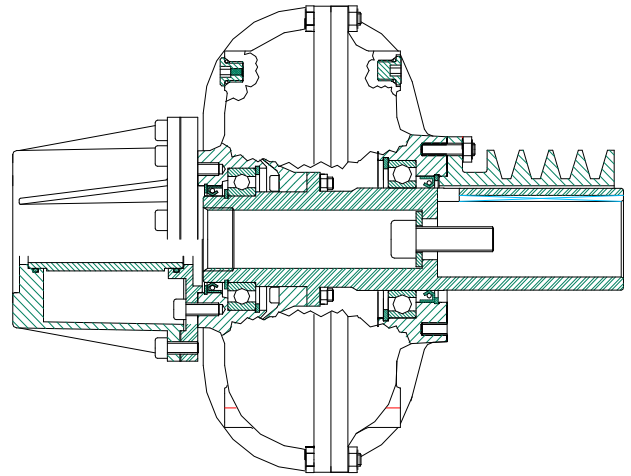

**PF R:** Version for flanged pulley and partial draining device (R)

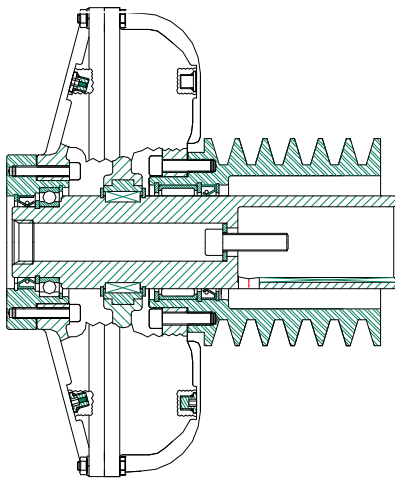

**PI:** With incorporated pulley

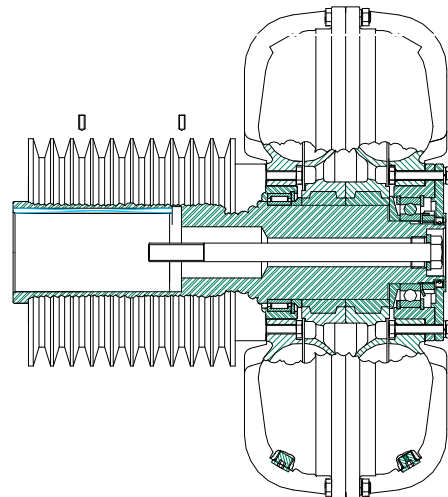

**PC:** Version for keyed pulley

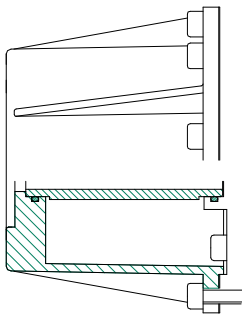

Partial draining device ( R )

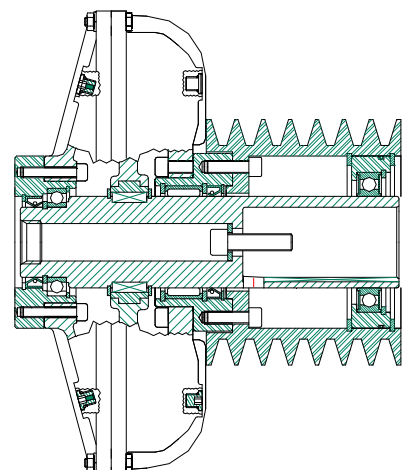

**PC CS**  
Pulley version

Knowing the input power and speed of the coupling, we use the diagram on page 5 (to select the right coupling).

For a continuous operation it is enough to consider the power demand of the driven machine.

For higher start-stop duty cycle and if the selection point (input speed/power) is close to the high limit of the band that defines the characteristics of the coupling, we have to select the net size up of the coupling and use high temperature seals.

The oil level must be adjusted to not overload the motor during the start.

## PERFORMANCE CALCULATION AND CHECK

### Data

- Speed of driven machine:  $n_2$  (RPM)

- Inertia:  $I$  ( $\text{kgm}^2$ )  $\left(\frac{PD^2}{4}\right) \text{ o } \left(\frac{GD^2}{4}\right)$

- Absorbed power:  $P_a$  (kW)

- Input speed:  $n_1$  (g/min)

- Ambient temperature:  $T$  ( $^{\circ}\text{C}$ )

**Inertia of driven machine to motor shaft =  $\text{kgm}^2$**

$$I_{n_1} = I \left(\frac{n_2}{n_1}\right)^2$$

**Coupling output speed = RPM.**

$$n_g = n_1 - s \quad (s = \text{slip})$$

You can get it from diagram input speed according to the absorbed torque  $C_c$  (Nm) or by using an average value from 5 to 3 (from small to big units)

**Motor power = Kw**  $P_m = \frac{I_{n_1} \cdot n_1^2}{9,12 \cdot 10^4 \cdot t_a}$   
 $t_a = \text{startin time}$

**Nominal torque = Nm**  $C_m = \frac{9550 \cdot P_m}{n_1}$

**Torque absorbed by driven machine= Nm**  $C_c = \frac{9550 \cdot P_a}{n_g}$

**Starting torque = Nm**  $C_a = 1,6 \cdot C_m - C_c$   
 For coupling with R reduce from 1,6 to 1,4

**Starting time = sec.**  $t_a = \frac{n_g \cdot I_{n_1}}{9,55 \cdot C_a}$

**Temperature generated during acceleration = K cal.**  $Q = \frac{n_g}{10^4} \left( \frac{I_{n_1} \cdot n_g}{76,5} + \frac{C_c \cdot t_a}{8} \right)$

**Thermal capacity of the coupling = (Mo) (K cal /  $^{\circ}\text{C}$ )**  
 Add metal + oil (see table)

## THERMAL CAPACITY

Coupling size	Metal K cal/ $^{\circ}\text{C}$	Oil K cal/ $^{\circ}\text{C}$
155	0.75	0.43
190	1.16	0.92
220	1.63	1.26
240 N	2.24	1.73
275 N	3.20	2.10
355	5.60	3.60
400	7.20	4.30
445	12.1	6.60
18	12.1	6.60
19S	17.4	12.3
19	17.4	12.3
110	33.7	23.7

**Increase of temperature during acceleration = ( $^{\circ}\text{C}$ )**

$$T_i = \frac{Q}{M_o}$$

### Factor K:

Fattore K ricavabile dalla tabella seguente:

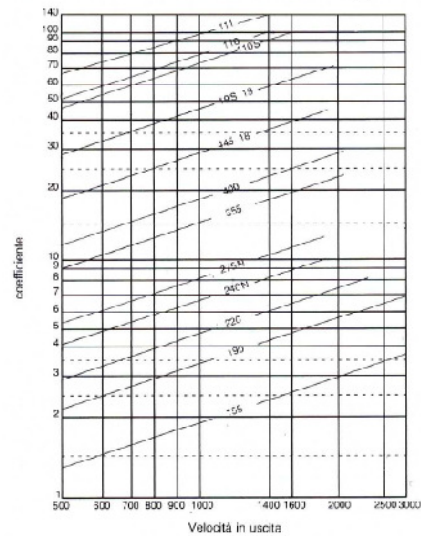

**Increase of temperature during starting running =  $^{\circ}\text{C}$**

$$T_{\Delta} = 2,4 \cdot \frac{P_a \cdot s}{K}$$

**Final temperature =  $^{\circ}\text{C}$**   $T_t = T + T_i + T_{\Delta}$

$T$ : ambient temperature

$T_t$ : has to be lower than  $110^{\circ}\text{C}$

For higher temperature and till  $175^{\circ}$ , special seals are necessary.

**Minimum working cycle for hour = sec**

$$t_w = 10^3 \cdot \frac{Q}{T_i \cdot K}$$

**Maximum working cycle for hour:**

$$A = \frac{3600}{t_a + t_w}$$

# SELECTION DIAGRAM

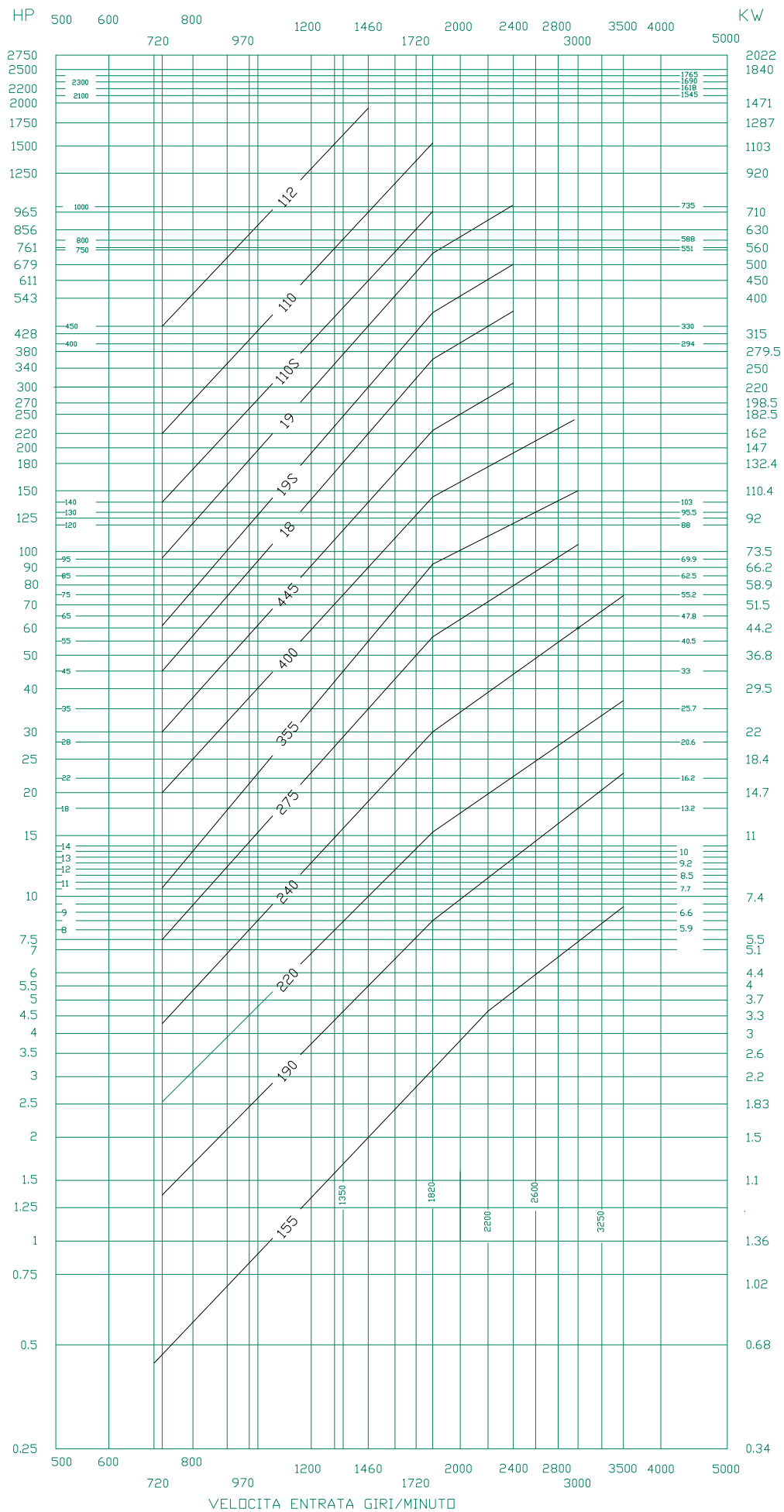

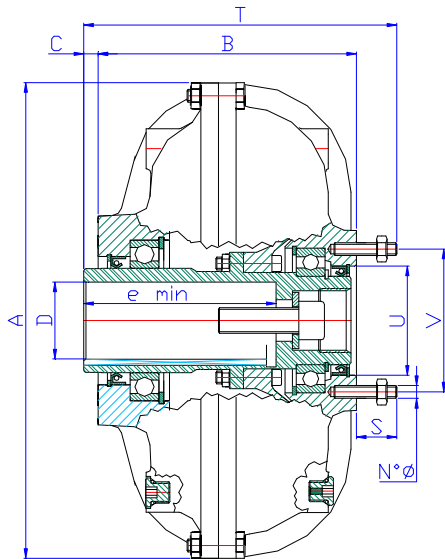

L/S VERSION: WITH STUD BOLTS

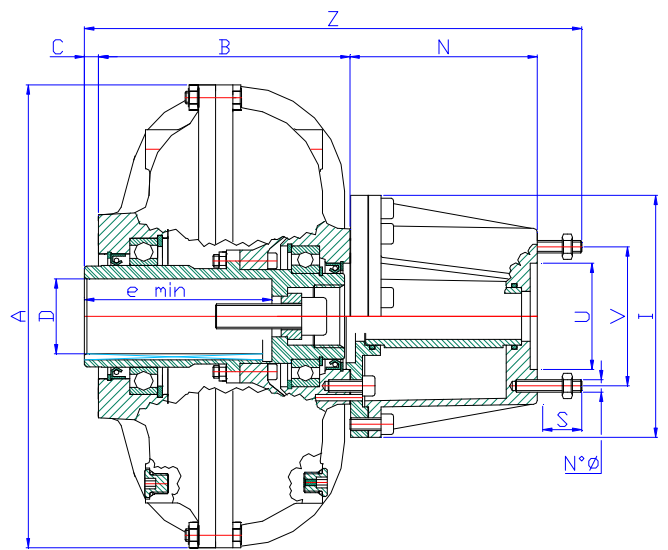

L/RS VERSION: WITH STUD BOLTS AND PARTIAL DRAINING DEVICE

COUPLING SIZE	DIMENSIONS												WEIGHTS WITHOUT OIL KG	
	A	B	C	D	e min	I	N	S	T	U	V	Z	LS	LRS
155	193	91	10	19 - 24 28*	40 - 50 60	126	104	16	117	40	52	221	3,1	3,6
190	232	113	10	19 - 24 28 - 38*	40 - 50 60 - 80	126	104	16	139 151	47	73	243 255	4,9	5,5
220	280	157	10	28 - 38 42 - 48*	60 - 80 110	156	99	25	192	62	89	291	9,5	10,5
240N	296	161	9	38 42 - 48	80 110	156	121	25	195	62 68	89	316	10,5	12
275N	340	176	25	48 - 55 60	110 140	186	140	30	231	72 90	112	371	25	29
355	430	190	15	48 - 55 60 - 65	110 140	186	140	30	235	72 85	112	375	29,5	35,5
400	468	197	23 43	55 60 - 65 75*	110 140 140	240	151	30	250 270	85	136	401 421	38	44
445	527	230	35	65 - 75 80	140 170	250	170	35	300	120	168	470	59	68
18	527	240	32	65 - 75 80	140 170	250	214	35	307	120	168	509	61	71
19S	626	236	54	75 80 - 90 100	140 170 210	290	220	45	355	140	196	555	87	100
19	626	261 316	20 15	80 - 90 100*-110*	170 210 - 230	290	267	45	326 376	140	196	570 620	93	108
110S	800	B + C 300		80 - 90 100 - 120	170 210	530	110	50	350	180	250	460	120	130
110	800	330	26	80 - 90 100 - 120	170 210	365	291	50	406	180	250	677	140	155
112														

- \* Special manufactured on request
- For the size 110 S and 112, consult manufacturer for recommendations
- Keyways as per UNI 6604-69 DIN 6885/1
- Fixing screws and washers as per DIN 332
- The weights and dimensions can be modified

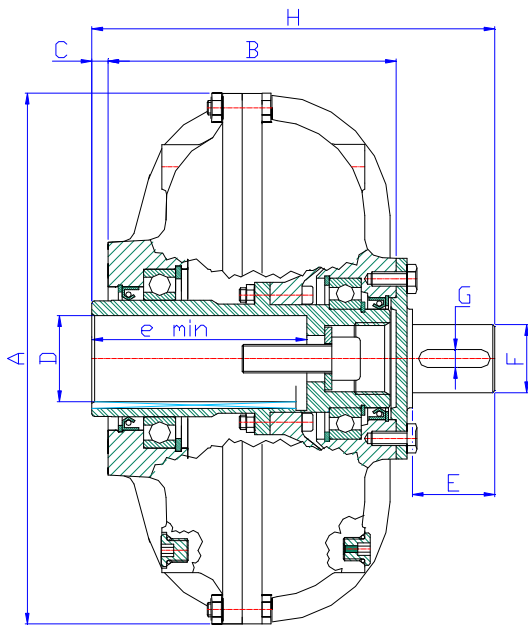

L/MU VERSION: WITH STUB SHAFT

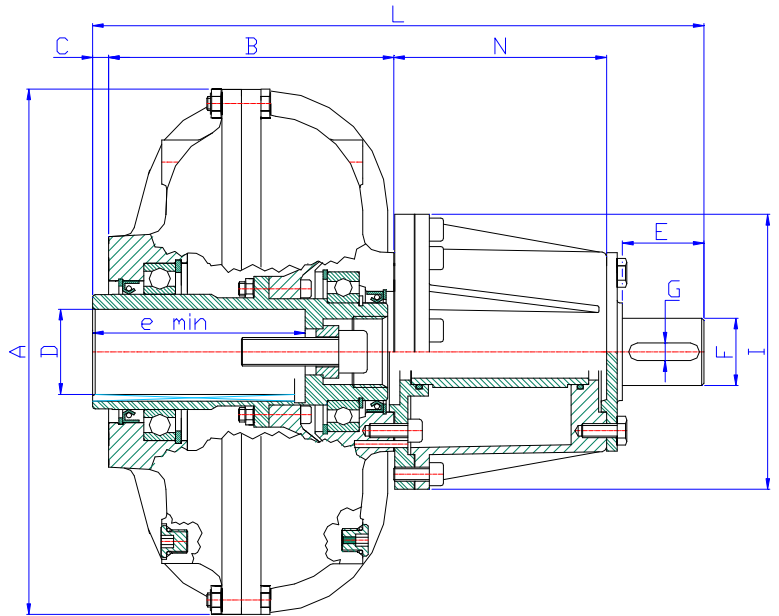

LR/MU VERSION: WITH STUB SHAFT AND PARTIAL DRAINING DEVICE

COUPLING SIZE	DIMENSIONS												WEIGHTS WITHOUT OIL	
	A	B	C	D	e min	E	F h6	G	H	I	L	N	L/MU	LR/MU
155	193	91	10	19 - 24 28*	40 - 50 60	30	19	6	139	126	243	104	3,2	3,7
190	232	113	10	19 - 24 28 - 38*	40 - 50 60 - 80	31 38*	24 38*	8 10	162 173*	126	266 277*	104	5	5,6
220	280	157	10	28 - 38 42 - 48*	60 - 80 110	46	38	10	221	156	320	99	10	11
240N	296	161	9	38 42 - 48	80 110	46	38	10	224	156	345	121	11	12,5
275N	340	176	25	48 - 55 60	110 140	66	48	14	277	186	417	140	26	30
355	430	190	15	48 - 55 60 - 65	110 140	66	48	14	281	186	421	140	31,5	36,5
400	468	197	23 43	55 60 - 65 75*	110 140 140	66	55	16	296 316	240	447 467	151	40	46
445	527	230	35	65 - 75 80	140 170	70	55	16	347	250	517	170	63	72
18	527	240	32	65 - 75 80	140 170	70	55	16	354	250	556	214	65	75
19S	626	236	54	75 80 - 90 100	140 170 210	85	70	20	401	290	621	220	91	104
19	626	261 316	20 15	80 - 90 100*-110*	170 210 - 230	85	70	20	392 441	290	636 686	267	100	115
110S	800	B + C 300		80 - 90 100 - 120	170 210	100	80	22	425	530	535	110	130	140
110	800	330	26	80 - 90 100 - 120	170 210	100	80	22	481	365	752	291	150	165
112	1100	382	52	MAX.180	320	**	**	**	//	601	687	253,5		

\*/\*\* Special manufactured on request  
 Keyways as per UNI 6604-69 DIN 6885/1  
 Fixing screws and washers as per DIN 332  
 Fixing screw and washers supplied on request  
 For sizes 110S and 112, consult manufacturer for recommendations  
 The weights and dimensions can be modified

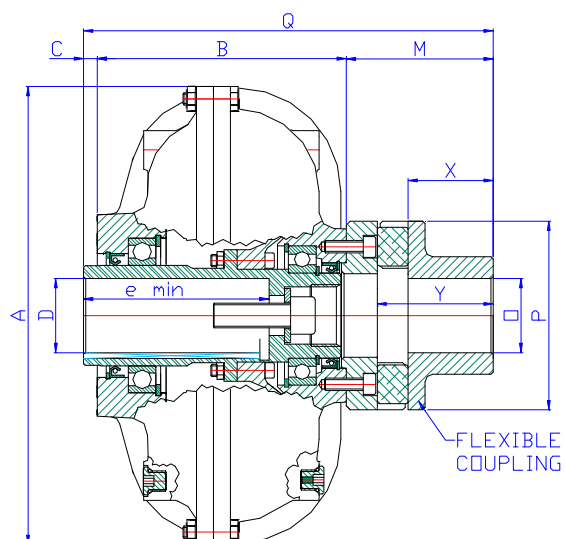

L/E VERSION: WITH FLEXIBLE COUPLING

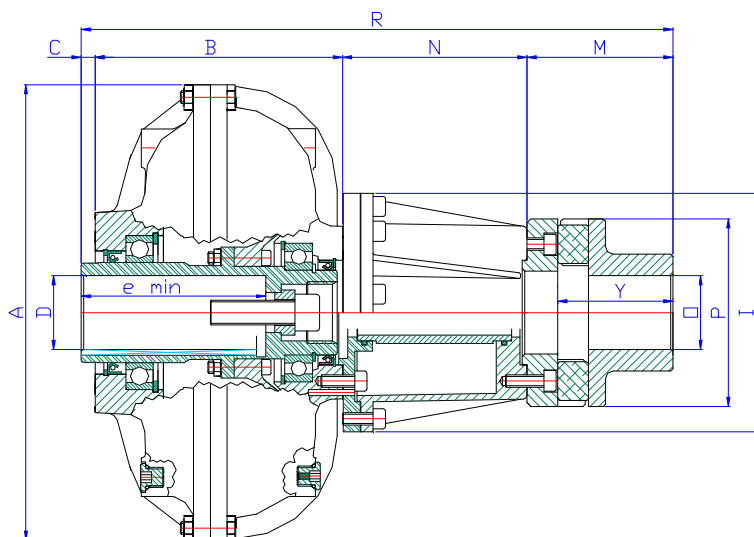

LR/E VERSION: WITH FLEXIBLE COUPLING AND PARTIAL DRAINING DEVICE

Coupling size	Flexible coupling	DIMENSIONS													Weights Kgs (Without oil)	
		A	B	C	D (G7)	e (min)	l	Q ± 1,5	R ± 1,5	M	N	X	O MAX	P	LE	LRE
155	E 10	193	91	10	19 - 24 28*	40 - 50 60	126	153	257	52	104	30	24	70	3,9	4,4
190	E 20	232	113	10	19 - 24 28 - 38*	40 - 50 60 - 80	126	199 277*	303 315	76	104	42	38	96	6,7	7,3
220	E 30	280	157	10	28 - 38 42 - 48*	60 - 80 110	156	262	361	95	99	55	48	122	12,5	14,5
240N	E 30	296	161	9	38 42 - 48	80 110	156	265	386	95	121	55	48	122	14,5	16
275N	E 40	340	176	25	48 - 55 60	110 140	186	320	460	119	140	73	60	150	31	35
355	E 40	430	190	15	48 - 55 60 - 65	110 140	186	324	463	119	140	73	60	150	35,5	40,5
400	E 50	468	197	23 43	55 60 - 65 75*	110 140 140	240	339 359	490 510	119	151	73	70	175	48	54
445	E 60	527	230	35	65 - 75 80	140 170	250	407	577	142	170	88	80	220	75	84
18	E 60	527	240	32	65 - 75 80	140 170	250	414	616	142	214	88	80	220	77	87
19S	E 70	626	236	54	75 80 - 90 100	140 170 210	290	471	691	181	220	110	100	250	113	126
19	E 70	626	261 316	20 15	80 - 90 100*-110*	170 210 - 230	290	462 512	706 756	181	267	110	100	250	119	134
110S	E 75	800	B + C 300		80 - 90 100 - 120	170 210	530	485	595	185	110	140	120	320	190	220
110	E 80	800	330	26	80 - 90 100 - 120	170 210	365	584	855	228	291	141	120	320	210	225
112	E100	1100	382	52	Max. 180	320	601		903	216	253,5		150	480		

\*Special manufactured on request

Keyways as per UNI 6604-69 DIN 6885/1

Fixing screws and washers as per DIN 332

Fixing screw and washers supplied on request -

For sizes 110S and 112, consult manufacturer for recommendations

The weights and dimensions can be modified

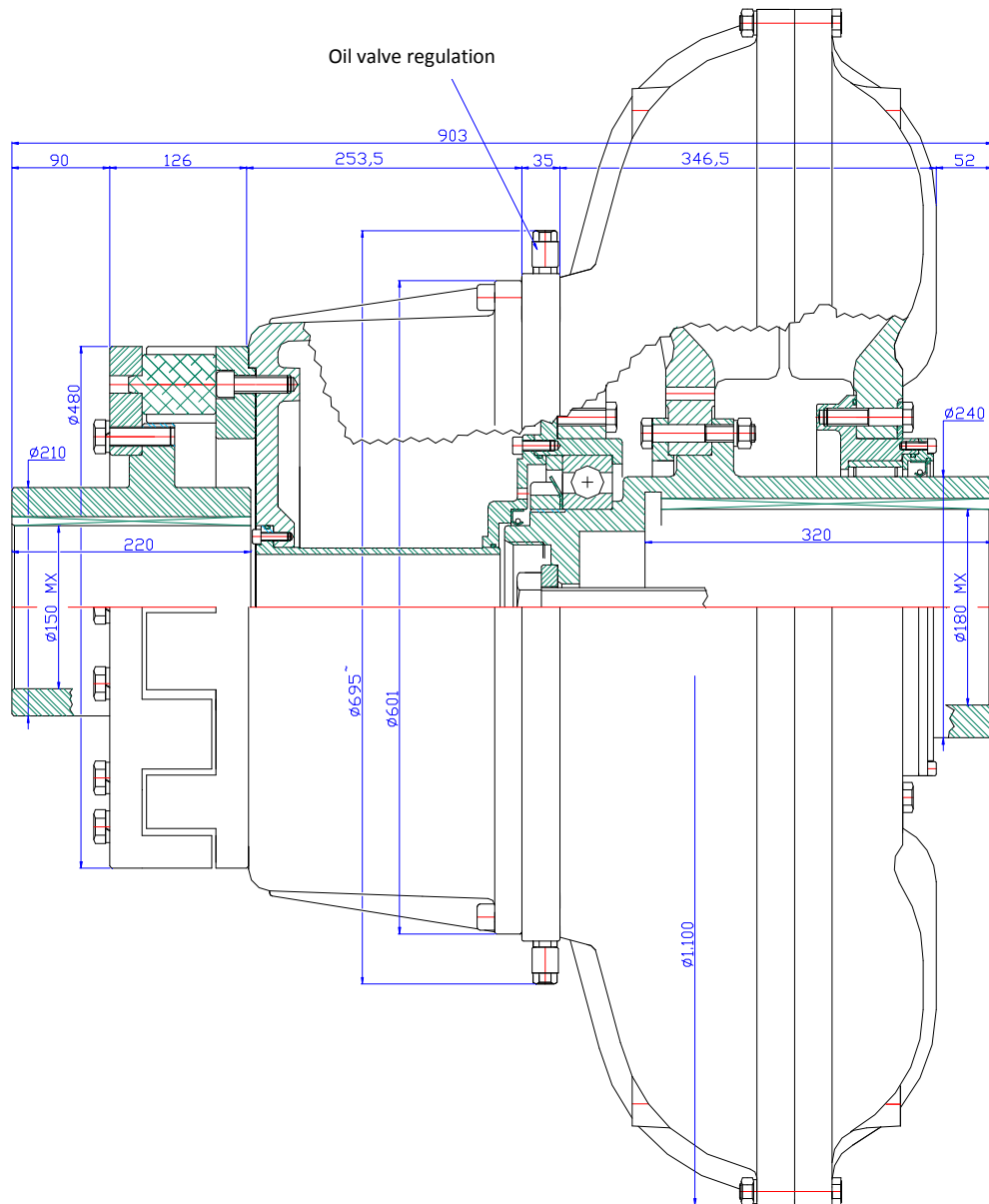

\*Special manufactured on request  
Keyways as per UNI 6604-69 DIN 6885/1  
Fixing screws and washers as per DIN 332  
Fixing screw and washers supplied on request  
The weights and dimensions can be modified

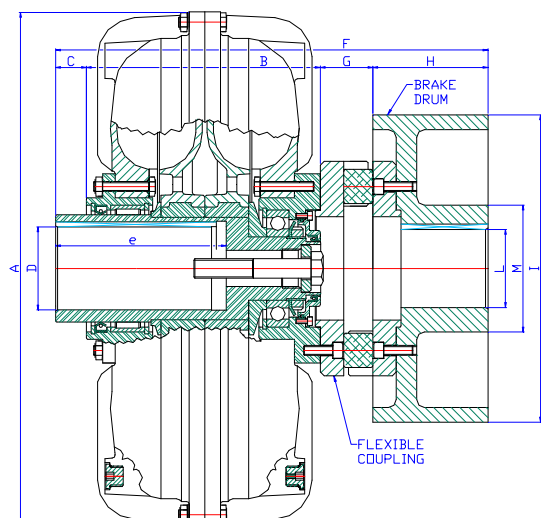

VERSION: L/E FF: WITH BRAKE DRUM

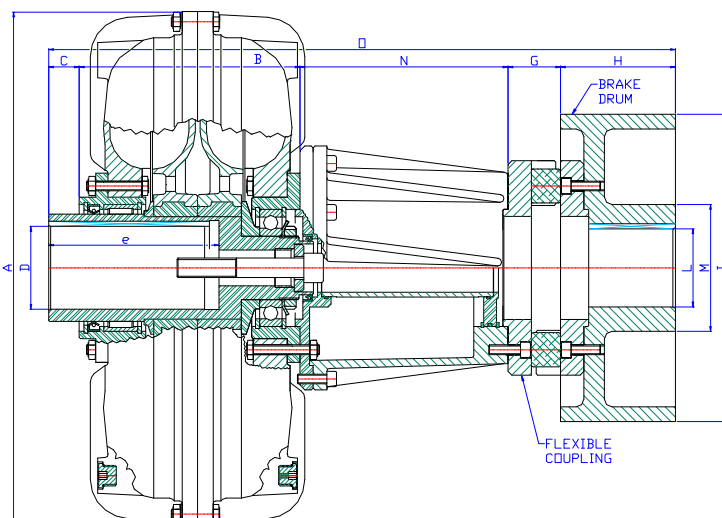

VERSION: LR/E FF: WITH BRAKE DRUM AND PARTIAL DRAINING DEVICE

Coupling size	DIMENSIONS												
	A	B	C	D (G7)	e (min)	F ±1,5	G	H	I	L G7	M	N	O ±1,5
155	193	91	10	19 - 24 28*	40 - 50 60	183	22	60	160	24	50	104	287
190	232	113	10	19 - 24 28 - 38*	40 - 50 60 - 80	217	34	60	160	28	60	104	321
220	280	157	10	28 - 38 42 - 48*	60 - 80 110	267	40	60	160	48	80	99	366
240N	296	161	9	38 42 - 48	80 110	285	40	75	200	48	80	121	406
275N	340	176	25	48 - 55 60	110 140	306 321	46	60 75	160 200	55	90	140	446 461
355	430	190	15	48 - 55 60 - 65	110 140	326 346	46	75 95	200 250	65	90	140	466 486
400	468	197	23	55 60 - 65 75*	110 140 140	362 385	47	95 118	250 315	65	110	151	513 536
445	527	230		35	65 - 75 80	140 170	437 469	54	118 150	315 400	80	130	170
18	527	240	32	65 - 75 80	140 170	444 476	54	118 150	315 400	80	130	214	646 678
19S	626	236	54	75 80 - 90 100	140 170 210	478 510	70	118 150	315 400	80	130	220	698 730
19	626	261 316	20 0	80 - 90 100*	170 210	501 541	70	150 190	400 500	90	160	267	745 785
110S	800	B + C 300		80 - 90 100 - 120	170 210	570	80	190	500	120	200	110	680
110	800	330	26	80 - 90 100 - 120	170 210	626	80	190	500	120	200	291	897
112	1100	382	52	Max. 180	320	//	126	//	//	150	210	253,5	903

\*Special manufactured on request

Keyways as per UNI 6604-69 DIN 6885/1

Fixing screws and washers as per DIN 332

Fixing screw and washers supplied on request

For sizes 110S and 112, consult manufacturer for recommendations

The weights and dimensions can be modified



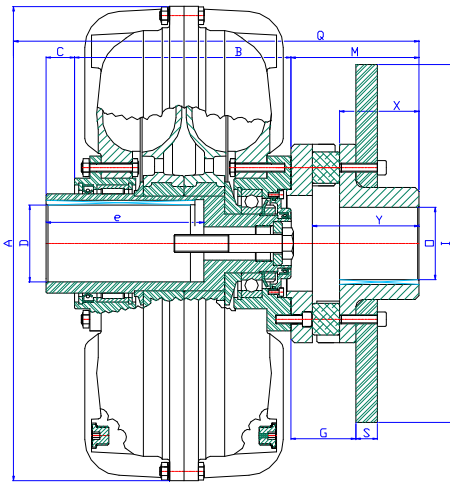

VERSION: L/E FF: WITH FLEXIBLE COUPLING AND BRAKE DISC

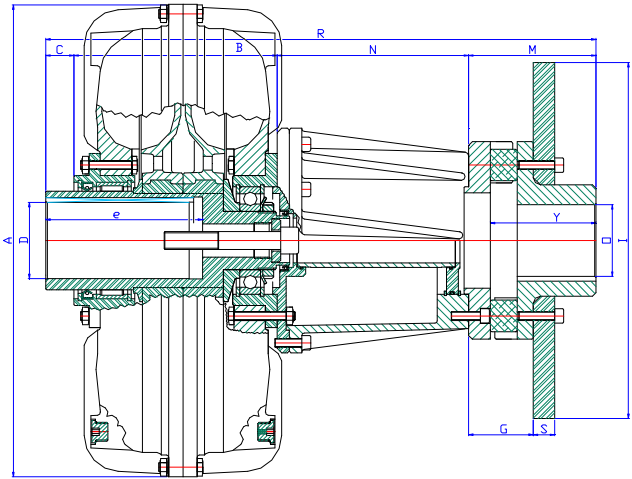

VERSION: LR/E FF: WITH FLEXIBLE COUPLING, PARTIAL DRAINING DEVICE AND BRAKE DISC.

Coupling size	DIMENSIONS												
	A	B	C	D (G7)	e (min)	Q ±1,5	G	S	I	O G7	M	N	R ±1,5
155	193	91	10	19 - 24 28*	40 - 50 60	183	30	**	**	24	52	104	287
190	232	113	10	19 - 24 28 - 38*	40 - 50 60 - 80	217	43	**	**	38	76	104	321
220	280	157	10	28 - 38 42 - 48*	60 - 80 110	267	51	**	**	48	95	99	366
240N	296	161	9	38 42 - 48	80 110	285	51	**	**	48	95	121	406
275N	340	176	25	48 - 55 60	110 140	306 321	61	**	**	60	119	140	446 461
355	430	190	15	48 - 55 60 - 65	110 140	326 346	61	**	**	60	119	140	466 486
400	468	197	23	55 60 - 65 75*	110 140 140	362 385	61	**	**	70	119	151	513 536
445	527	230	35	65 - 75 80	140 170	437 469	72	**	**	80	142	170	607 639
18	527	240	32	65 - 75 80	140 170	444 476	72	**	**	80	142	214	646 678
19S	626	236	54	75 80 - 90 100	140 170 210	478 510	93	**	**	100	181	220	698 730
19	626	261 316	20 0	80 - 90 100*	170 210	501 541	93	**	**	100	181	267	745 785
110S	800	B+C 300		80 - 90 100 - 120	170 210	570	130	**	**	120	185	110	680
110	800	330	26	80 - 90 100 - 120	170 210	626	130	**	**	120	228	291	897
112	1100	382	52	Max. 180	320	//	126	**	**	150	216	253,5	903

\*/\*\* Special manufactured on request  
 Keyways as per UNI 6604-69 DIN 6885/1  
 Fixing screws and washers as per DIN 332  
 Fixing screw and washers supplied on request -  
 For sizes 110S and 112, consult manufacturer for recommendations  
 The weights and dimensions can be modified

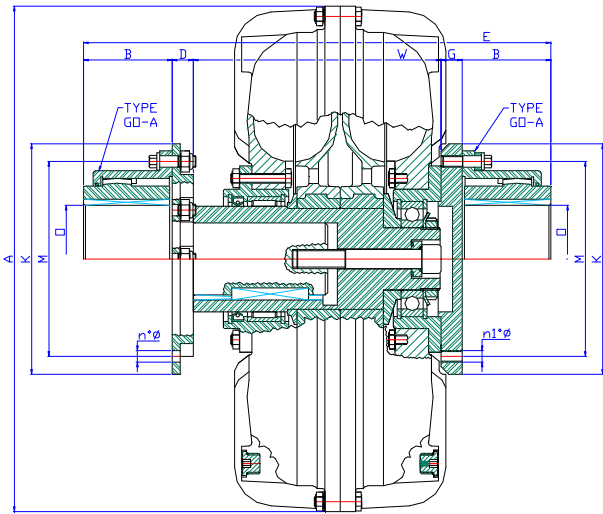

VERSION:CF FOR HALF GEAR COUPLING

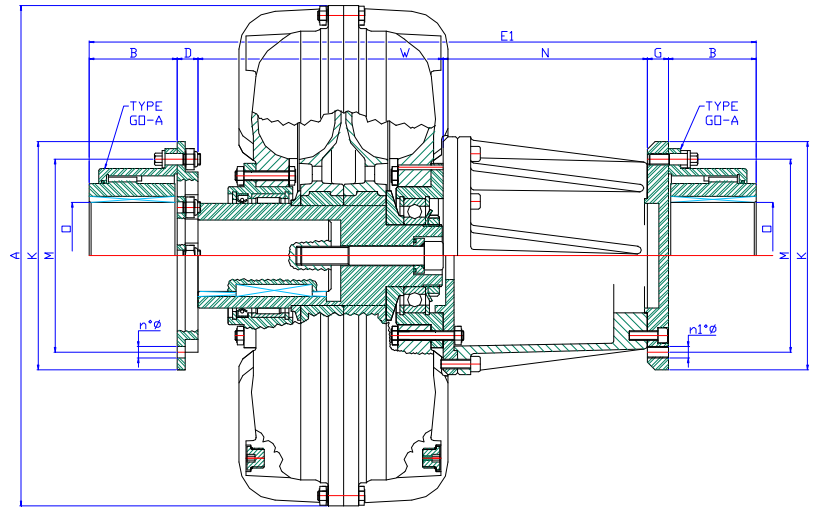

VERSION:CF FOR HALF GEAR COUPLING WITH PARTIAL DRAINING DEVICE

COUPLING SIZE	DIMENSIONS													WEIGHTS WITHOUT OIL	
	A	E ±1	E1 ±1,5	B	D	G	W	M ±0,2	K	O MAX	P	N° Ø	N°1 Ø	CF	CFR
155	193	222	326	44,5	16	16	101	96	116	44	104	6 8	6 M8	5,4	5,9
190	232	244	348	44,5	16	16	123	96	116	44	104	6 8	6 M8	7,2	7,8
220	280	308	407	51,5	19	19	167	122	152	60	99	8 10	8 M10	15,5	16,5
240N	296	335	456	63,5	19	19	170	148	180	75	121	10 10	10 M10	19	20,5
275N	340	402	542	78,5	22	22	201	178	215	95	140	10 12	10 M12	39	43
355	430	406	546	78,5	22	22	205	178	215	95	140	10 12	10 M12	43,5	48,5
400	468	421	572	78,5	22	22	220	178	215	95	151	10 12	10 M12	52	58
445	527	494	664	92,5	22	22	265	203	240	110	170	12 12	12 M12	80,5	89,5
18	527	489,5	703,5	92,5	22	22	260,5	203	240	110	214	12 12	12 M12	82,5	92,5
19S	626	564	784	108	28,5	28,5	291	236	280	132	220	12 16	12 M16	122	135
19	626	531	798	108	28,5	28,5	258	236	280	132	267	12 16	12 M16	128	143
110S	800	603	713	123	28,5	28,5	300	270	320	150	110	14 16	14 M16	185	200
110	800	639,5	930,5	123	28,5	28,5	336,5	270	320	150	291	14 16	14 M16	185	200
112	1100														

\*/\*\* Special manufactured on request  
 Half gear coupling supplied on request  
 Keyways as per UNI 6604-69 DIN 6885/1  
 Fixing screws and washers as per DIN 332  
 Fixing screw and washers supplied on request -  
 For sizes 110S and 112, consult manufacturer for recommendations  
 The weights and dimensions can be modified

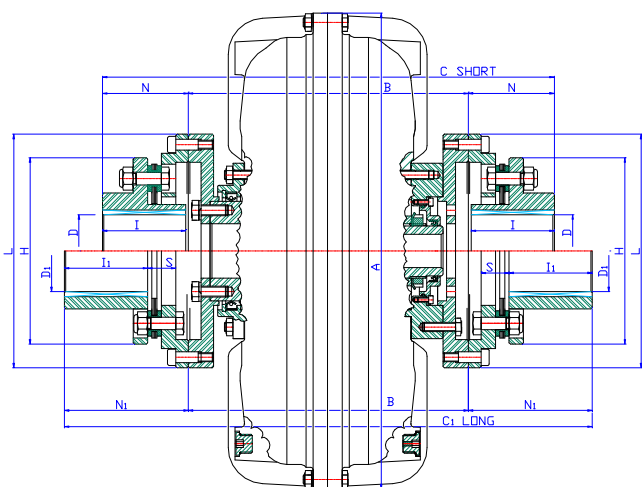

VERSION: CF-LS FOR ALL METAL FLEXIBLE COUPLING

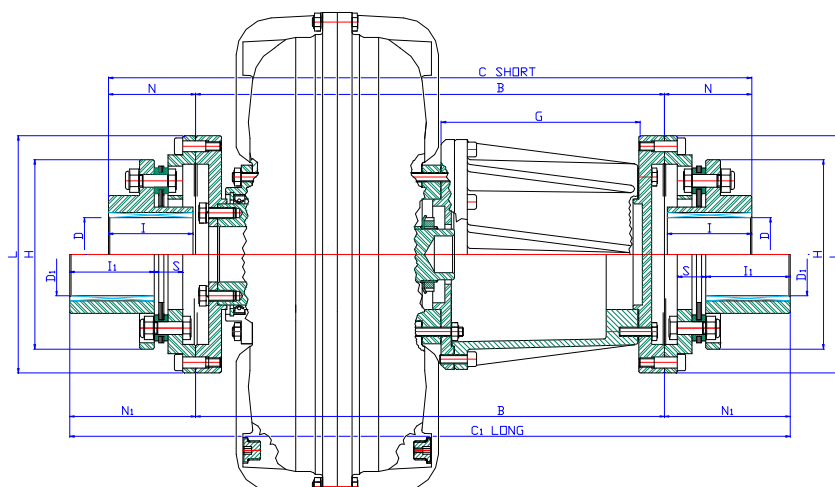

VERSION: CF FOR ALL METAL FLEXIBLE COUPLING WITH PARTIAL DRAINING DEVICE

Coupling size	A	B	C ±1,5	N	I	D max	C1 ±1,5	N1	G	I1	D1 max	S	H	L	Flexible Coupling
220 CF-LS	280	291	391	50	42	38	421	65	99	42	42	16	92	125	LS-150
240N CF-LS	296	321	443	61	50	48	487	83	119	50	55	24	136	180	LS-700
275N CF-LS	340	341	463	61	50	48	507	83	140	50	55	24	136	180	LS-700
355 CF-LS	430	350	492	71	60	60	546	98	140	60	65	26	162	198	LS-1100
400 CF-LS	468	369	533	82	80	70	607	119	151	80	75	30	182	228	LS-1700-6
445 CF-LS	526	428	616	94	92	80	702	137	170	92	90	30	206	258	LS-2600-6
18 CF-LS	526	510	712	95	92	80	784	137	214	92	90	30	206	258	LS-2600-6
19S CF-LS	626	532	786	127	100	90	850	159	220	100	100	40	225	290	LS-4000-6
19 CF-LS	626	619	893	137	120	110	989	185	267	120	110	50	250	340	LS-7000-6
110S CF-LS	800	477	797	160	143	110	847	185	110	120	110	60	250	340	LS-7000-6
110 CF-LS	800	689	1025	168	120	110	1129	220	300	140	130	60	296	385	LS-9000-6

\*/\*\* Special manufactured on request

Keyways as per UNI 6604-69 DIN 6885/1

Fixing screws and washers as per DIN 332

Fixing screw and washers supplied on request -

For sizes 110S and 112, consult manufacturer for recommendations

The weights and dimensions can be modified

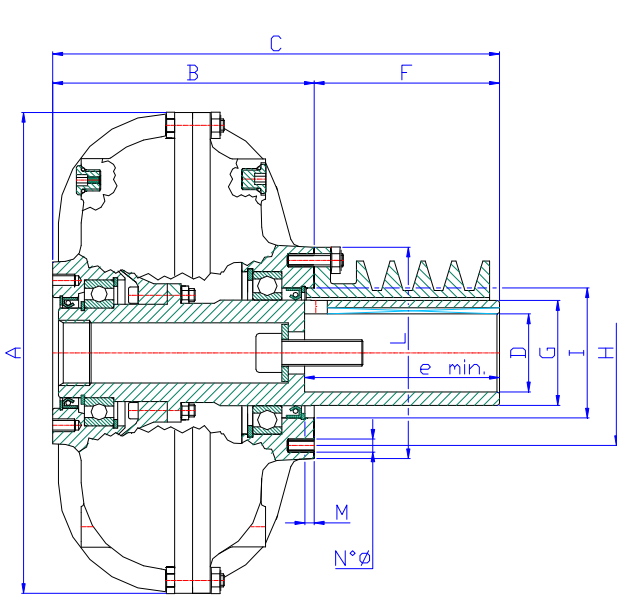

VERSION PF: FOR FLANGED PULLEY

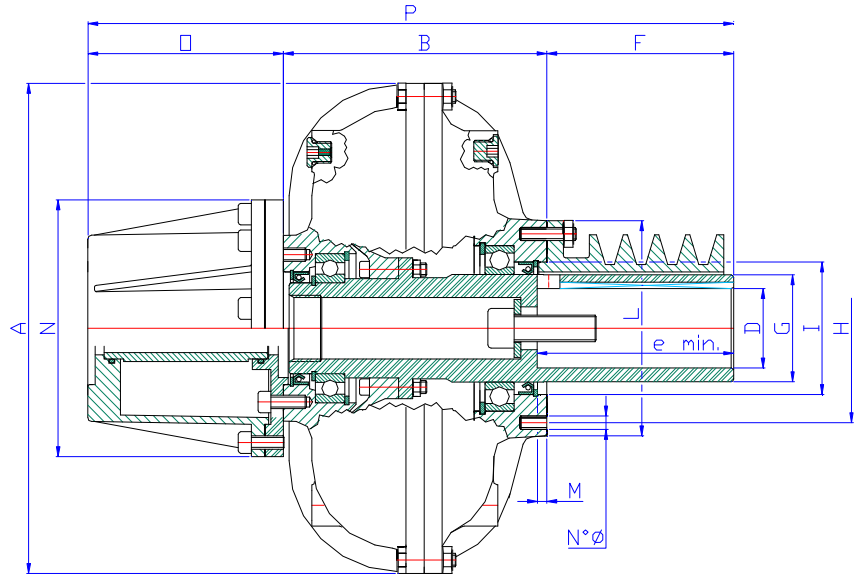

VERSION PF/R: FOR FLANGED PULLEY AND PARTIAL DRAINING DEVICE.

COUPLING SIZE	DIMENSIONS														Stud bolts		E
	A ± 1	B ± 1	C ± 1	D G7	e min	F ± 1	G	H ± 0,2	I G7	L	M	N	O	P ± 1,5	N°	∅	
155	193	91	147 163	19 - 24 28*	40 - 50 60	56 72	35 40	75	62 68	85	6	126	104	251 267	6	M6	17
190	232	113 125	169 185 181-197	19 - 24 28 38*	40 - 50 60 80	56 72 72	40 40 55	80	55 65	95	6	126	104	273 289 301	6	M6	17
220	280	157	271	38 - 42 48*	80 - 110 110	114	56	105	90 95	130	6	156	99	370	8	M8	25
240N	296	161	275 292	38 - 42 48	80 - 110 110	114 131	65	114	80	130	6	156	121	396 413	8	M8	25
275N	340	176	325	48 - 55 60	110 140	149	75	150	130	165	7	186	140	465	8	M10	30
355	430	202	357	48 - 55 60 - 65	110 140	155	85	140	105	165	7	186	140	497	8	M12	30
400	468	225	380	55 60 - 65 75*	110 140 140	155	85 95	140	105 115	165	7	210	151	531	8	M12	30
445	527	262	442	65 - 75 80	140 170	180	110	170	130	190	7	250	170	612	8	M12	30
18 PF	527	308	498	65 - 75 80	140 170	190	110	190	170	210	7	250	214	712	10	M12	30
19 SF	626	266	456	75 80 - 90	140 170	190	120	205	180	226	7	290	220	676	10	M12	30
110S	800	330	585	80 - 90 100 - 120	170 210	255	150	240	210	265	6	530	110	695	12	M12	30

\*/\*\* Special manufactured on request

Keyways as per UNI 6604-69 DIN 6885/1

Fixing screws and washers as per DIN 332

Fixing screw and washers supplied on request -

For sizes 110S and 112, consult manufacturer for recommendations

The weights and dimensions can be modified

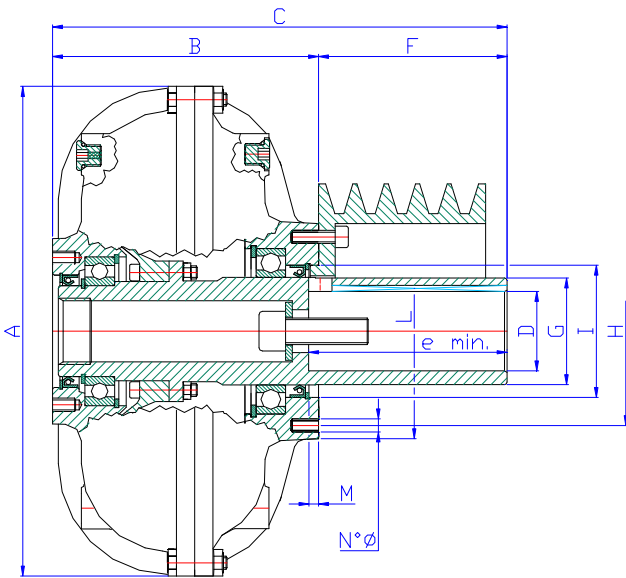

VERSION PT: HOLLOWED PULLEY

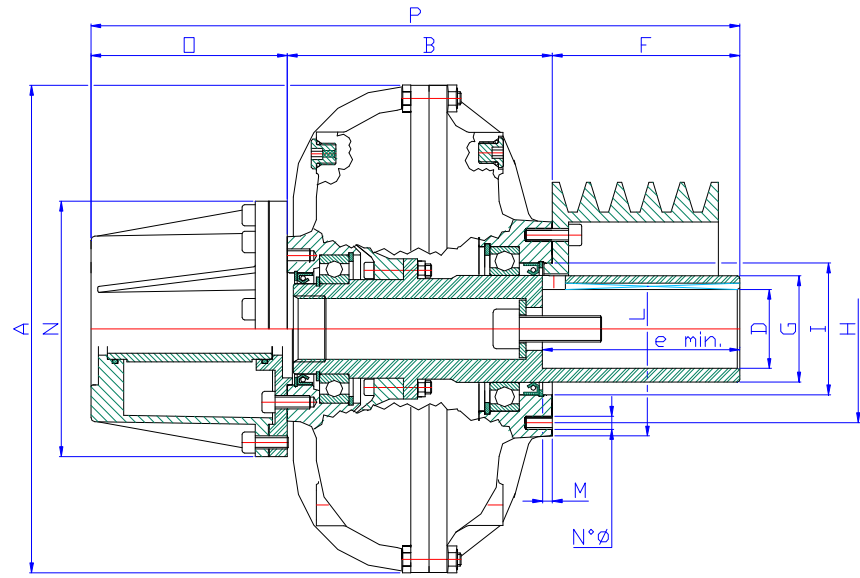

VERSION PT/R: HOLLOWED PULLEY AND PARTIAL DRAINING DEVICE

Coupling size	DIMENSIONS														Stud bolts		E
	A	B	C	D	e	F	G	H	I	L	M	N	O	P	N°	∅	
	± 1	±1	±1	G7	min	±1	G	±0,2	G7					±1,5			
155	193	91	147 163	19 - 24 28*	40 - 50 60	56 72	35 40	75	62 68	85	6	126	104	251 267	6	M6	17
190	232	113 125	169 185 181-197	19 - 24 28 38*	40 - 50 60 80	56 72 72	40 40 55	80	55 65	95	6	126	104	273 289 301	6	M6	17
220	280	157	271	38 - 42 48*	80 - 110 110	114	56	105	90 95	130	6	156	99	370	8	M8	25
240N	296	161	275 292	38 - 42 48	80 - 110 110	114 131	65	114	80	130	6	156	121	396 413	8	M8	25
275N	340	176	325	48 - 55 60	110 140	149	75	150	130	165	7	186	140	465	8	M10	30
355	430	202	357	48 - 55 60 - 65	110 140	155	85	140	105	165	7	186	140	497	8	M12	30
400	468	225	380	55 60 - 65 75*	110 140 140	155	85 95	140	105 115	165	7	210	151	531	8	M12	30
445	527	262	442	65 - 75 80	140 170	180	110	170	130	190	7	250	170	612	8	M12	30
18 PF	527	308	498	65 - 75 80	140 170	190	110	190	170	210	7	250	214	712	10	M12	30
19 SF	626	266	456	75 80 - 90	140 170	190	120	205	180	226	7	290	220	676	10	M12	30
110S	800	330	585	80 - 90 100 - 120	170 210	255	150	240	210	265	6	530	110	695	12	M12	30

\*/\*\* Special manufactured on request

Keyways as per UNI 6604-69 DIN 6885/1

Fixing screws and washers as per DIN 332

Fixing screw and washers supplied on request -

For sizes 110S and 112, consult manufacturer for recommendations

The weights and dimensions can be modified

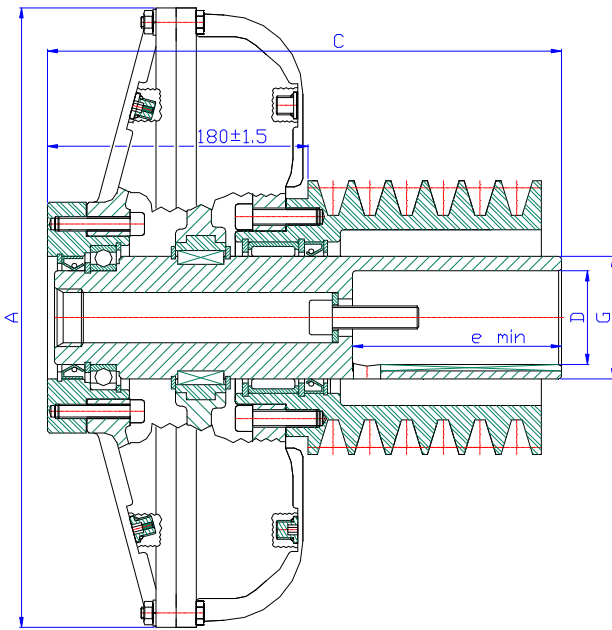

PI VERSION: WITH INCORPORATED PULLEY

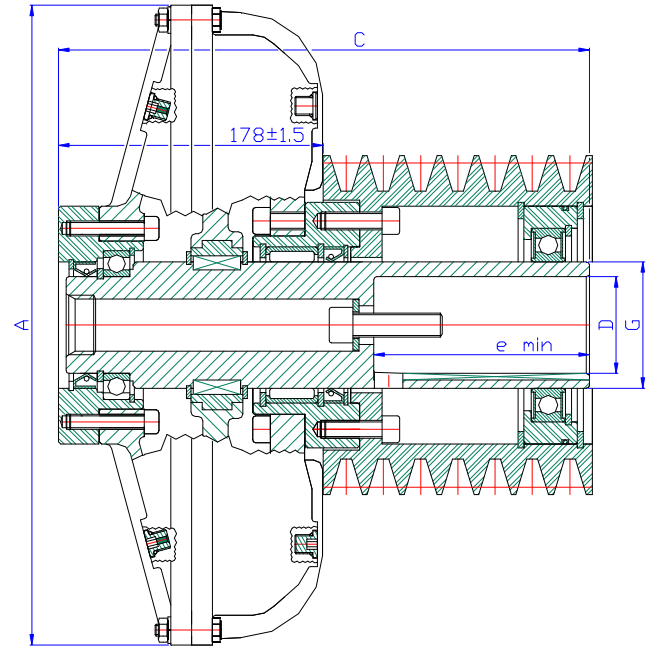

P-CS VERSION: WITH INCORPORATED PULLEY HAVING HIGH GROOVES NUMBER

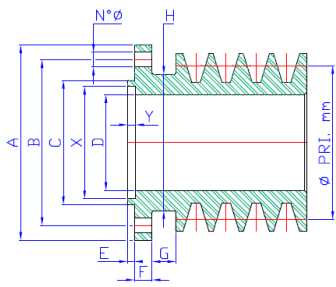

FLANGED PULLEY

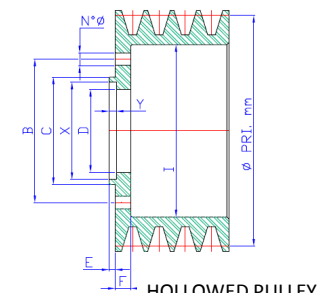

HOLLOWED PULLEY

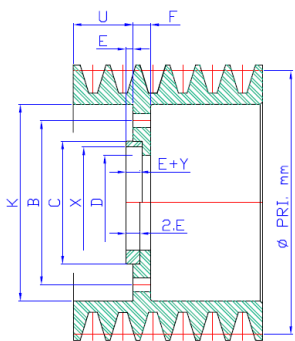

SPECIAL VERSION HOLLOWED PULLEY

COUPLIN G SIZE	DIMENSIONS														PULLEY		
	A	B ±0,2	C g6	D min	E ±0,1	F	G	H	I min	K	U	X	Y	N°	Ø	Flanged P.D. min	Hollowed P.D. min
155	85	75	62	36-41*	4	5	14	60	86					6	6,5	A 65-70* B 75-80*	A115 B125
190	95	80	55	41-57*	5	5	14	66	95					6	6,5	A 70-88* B 80-95*	A125 B135
220	130	105	90-95*	57-62*	5-10*	10	16	85	100-110*					8 8,5		A 90-95* B 95-100*	A155 B165
240N	130	114	80	67	5	10	16	85	130					8 8,5		A 98 B 105	A162 B170
275N	165	150	130	77	6	14	20	125	168			120	7	8 10,5		B 120 C 128	B210 C218
355	165	140	105	87	6	15	20	115	160	166	23			8 12,5		B 130 C 140	B205 C210
400	165	140	105	87-97*	6	15	20	115	160	176	33			8 12,5		B 130-140 C 140-150	B205 C210
445	190	170	130	112	6	15	20	145	190	191	44			8 12,5		B 160 C 170	B235 C250
18 PF	210	190	170	112	6	15	20	155	210	211	66	150	7	10	12,5	B 160 C 170	B255 C268
19 SF	225	205	180	112	6	20	20	160	225	226	34	160	7	10	12,5	C 180	C280
110 SF	265	240	210	153	4	20	20	215	260	270	34			12	12,5	C 220	320

NB: \* Suitable dimension for Ø input shaft mentioned by \* column D table page 18

\*/\*\* Special manufactured on request

Keyways as per UNI 6604-69 DIN 6885/1

Fixing screws and washers as per DIN 332

Fixing screw and washers supplied on request -

For sizes 110S and 112, consult manufacturer for recomentations

The weights and dimensions can be modified

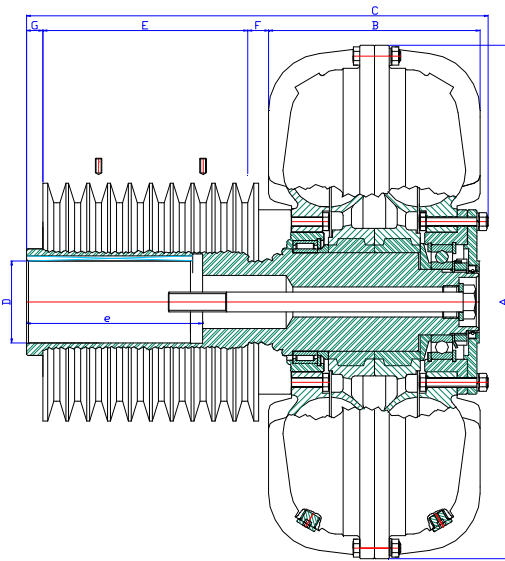

PC VERSION: FOR KEYED PULLEY

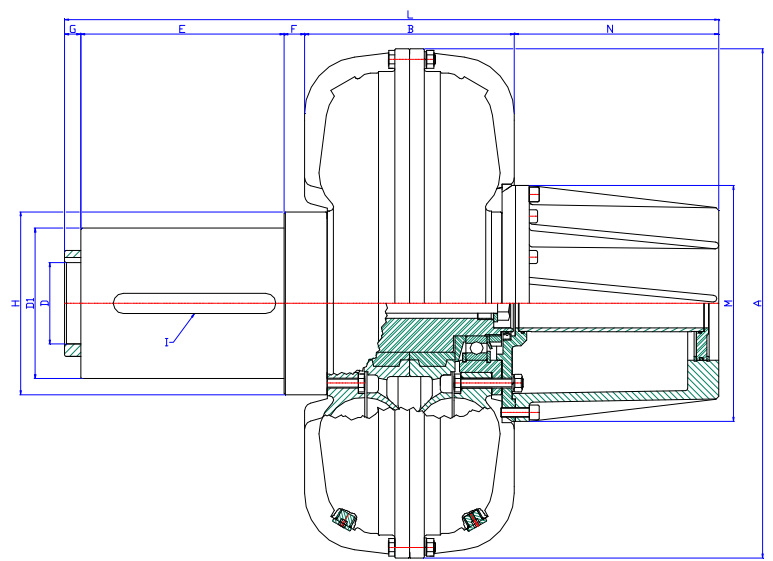

PC - R VERSION: FOR KEYED PULLEY AND PARTIAL DRAINING DEVICE

COUPLING SIZE	DIMENSIONS												
	A	B ±2	C ±2	D G7	e min	Di h6	E	F ±1	G	H	I	L ±2	M
18	527	240	516	65 - 75 80 - 90	140 170	160	220	20	31,5	195	20	708	250
19S	626	220	535	80 - 90 100	170	185	307	7 - 8	0	225	25	755	290
19	626	260	568	80 - 90 100	170 210	185	250	24	20	225	25	805	290
110S	800	190	610	80 - 90 100 - 120	170 210	220	300	18	2	275	25	720	530
110	800	350	670	80 - 90 100 - 120	170 210	260	300	15	5	290	25	951	365
112	1100												

IMPORTANT: For version PC-R, when mounting is vertical axis, it is essential for the coupling to be placed under the motor.  
The weights and dimensions can be modified.

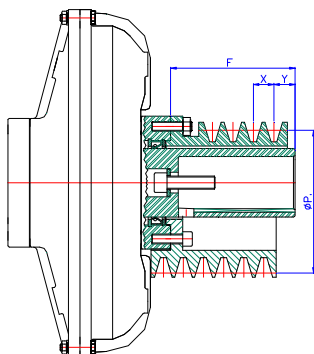

COUPLING SIZE	F	N° Grooves	∅ Pr	Y	X	Weight Kgs
155	56	2A - 2SPA	70 - 80 - 100	12	15	1 ÷ 1,3
190	56   72	2A   3A	90 - 100	12   13	15	1,4 ÷ 2
		2 SPA   3SPA	125* - 150*	31   32		
220 240	114	5 A - 5 SPA	112	18	15	4 ÷ 5
		4 B - 4 SPB	125 - 150	18,5		
		3 B - 3 SPB	180*	63,5		
275N	149	5 B - 5 SPB	150	26,5	19	7 ÷ 12
		4 B - 4 SPB	180	45,5		
		4 C - 4 SPC	224*	55,5		
355	155	6 B - 6 SPB	150 - 180	12,5	19	9 ÷ 11
			205	47,5		
400	155	6 B - 6 SPB	180	12,5	19	9 ÷ 25
			5 C - 5 SPC	250* - 280*		
445	180	10 B - 10 SPB	250*	31	19	25 ÷ 45
			300*			

During start the hydrodynamic couplings with the standard oil level do not allow the produced torque to increase above 200% of motor rated torque.

It is possible to reduce this limit further without reducing the quantity of oil by using the device R which, when the coupling is stationary, collects some of the oil from the circuit.

During start the low level of oil facilitates the fast acceleration of the electric motor and causes the coupling to transmit a very limited torque ( phase1 ).

Subsequently the oil contained in the tank of the device R is gradually brought into the circuit by the internal movement through the calibrated holes of the diagram situated between the device R and the coupling ( phase 2 ).

When the driven machine is up to operating speed, all the oil is into the coupling which is now capable to produce the maximum work ( phase 3 ).

With the device R the starting torque can therefore be reduced to 140% of the rated motor torque.

The use of the option is suggested for the starting of:

- Machines with high inertia
- Machines driven at high speed
- Machines that require soft starting.

All the Hydrodynamic Turbostart models can be fitted with the device R ( VD excepted ).

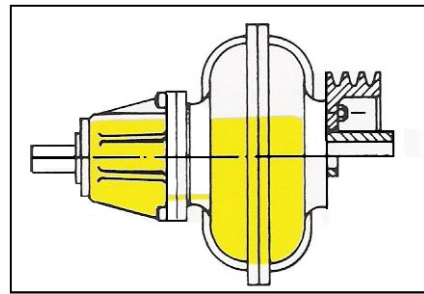

Oil level at rest (phase 1)

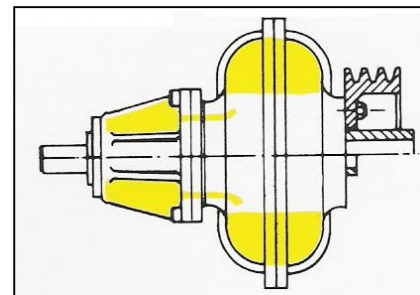

Oil level at startup (phase 2)

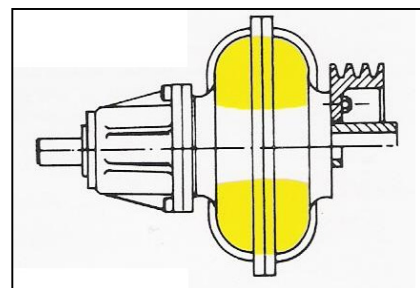

Oil level during work (phase 3)

Acceleration torque of Turbostart Hydrodynamic Coupling

- A with standard circuit
- B with partial draining device

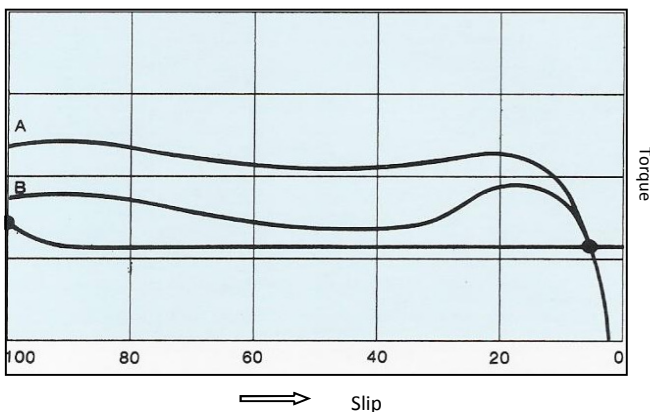

### Part numbering system

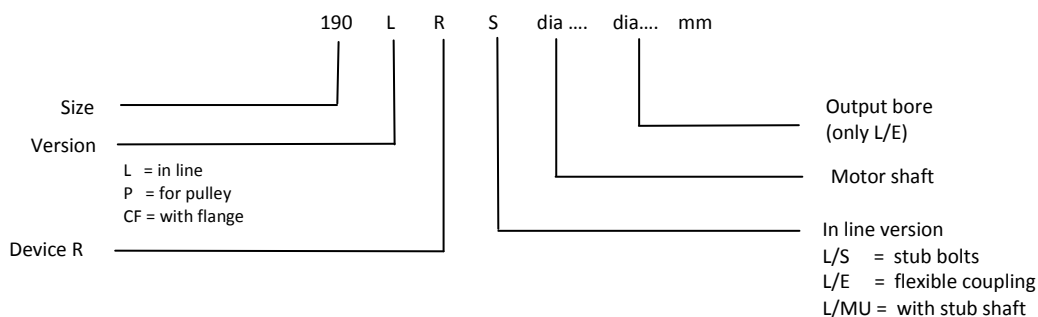



On request hydrodynamic and hydromechanic Turbostart couplings can be supplied with protecting devices for the protection of the coupling against possible extended overloads.

In case of extended overloads the high slip produced causes the oil temperature to rise triggering the protective device which can be used to stop the machine or give an acoustic or visible alarm.

**THERMAL TRIGGER DEVICE**

At a certain predetermined temperature the little piston leaves its seat and acts on a limit switch, stopping the machine or giving a warning signal. The device is reset by replacement of this trigger plug.

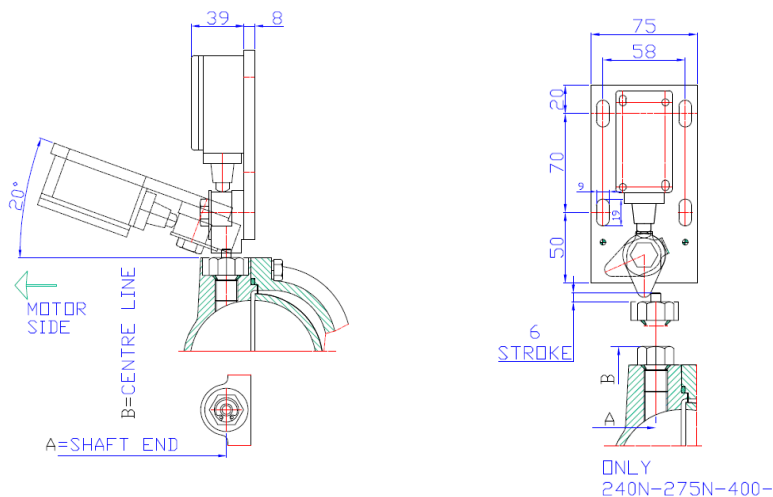

SHUT DOWN WIRING DIAGRAM

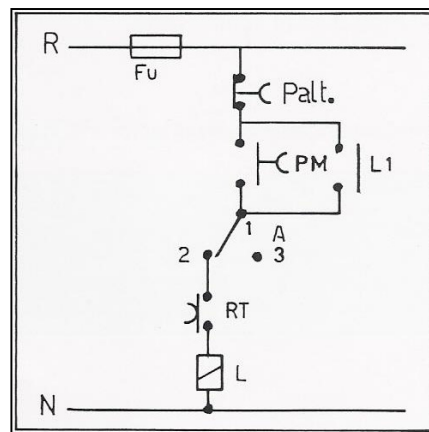

ALARM SYSTEM WIRING DIAGRAM

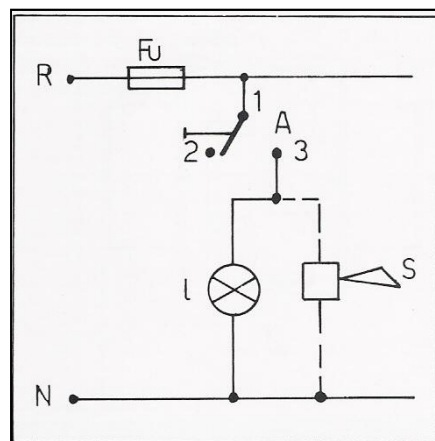

Coupling size	A ±1,5	B ± 1	Coupling size	A ±1,5	B ± 1
240 N	L 66	161	18	L 128	263,5
	P 169,5			P 367,5	
275 N	L 91	181,5		PF 345,5	
	P 214		19S	L 165	313
355	L 92	202		P 330	
	P 242,5		19	L 121,5	313
400	L 75	247		P 403	
	P 235,5		110	L 162	400
445	L 135,5	263,5		P 470	
	P 312,5				
110S	L 154	400			
	P 463				

**FUSIBLE PLUG DEVICE**

At the selected temperature( 145°C or 175°C) the fusible material of the plug melts and the oil gets out of the coupling and causes the transmission stall

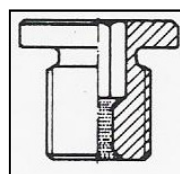

Fusible plug at 145° or 175° on request

## INSTALLATION

- Lubricate the surfaces to be assembled with oil or antiseize grease.
- Check that the connection to the driven shaft is slightly loose but precise to avoid vibrations.

### Model with pulley P

- After having checked the correct balancing, assemble the pulley on the hydrodynamic coupling.
- Secure the coupling on the shaft with the fixing screw B and washer C (fig. 1)
- Check pulley alignment and belt tension to avoid bearing damage.

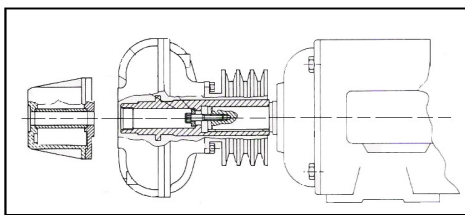

Draining device with through hole

Fig. 1

### In line model L

- Remove the flexible coupling (L/E) or remove the output shaft (L/MU).
- Secure the hydrodynamic coupling on the shaft with the fixing screw B and washer C (fig. 2)

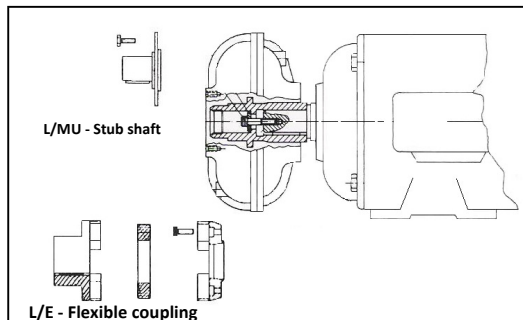

and testing with the guage every 90°, the T.I.R. difference should be within 35 ' of one angular degree. A good alignment prevents premature wear of the flexible coupling element.

### Models with the delay chamber device " R"

- Proceed as per models P or L. The coupling is fixed on the shaft with the fixing screw through the hole in the device (fig. 1)

## DISASSEMBLY

- Remove the fixing screw and washer (B, C) and with the puller dislocate the coupling from the shaft (fig. 3).
- Arrest the housing with a spanner on nut ring and screw the puller.

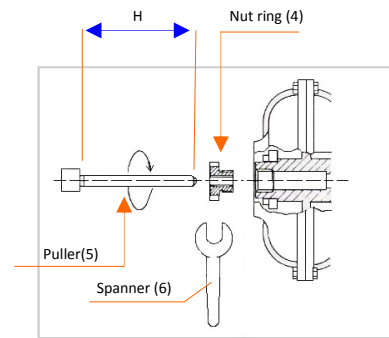

(parts 4 - 5 - 6 are supplied on request )

### PULLER

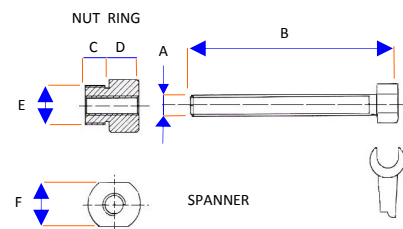

- Refit the flexible coupling on the driven shaft (L/E) or reinstall the output shaft (L/MU)
- Align the electric motor to the machine leaving 2 ± 3 mm. gap in the flexible coupling (L/E)
- Check the radial alignment of the flexible coupling by making sure that the alignment of the external machined surfaces are within 0,5 mm. maximum using a rule.
- Check with a feeler guage the angular alignment of the flexible coupling by turning the coupling 360°

Couplig size	A	B	C	D	E	F
155 190	M12	250	10	20	M26xp.2 left	Key 28
Da 220 a 110	M24	450	15	55	M40xp.2 left	Key 42
111	M45	700	—	—	—	—

## OIL FILLING

The Turbostart hydrodynamic coupling are normally supplied complete with oil filling and ready to put into operation. To refill the oil during maintenance, proceed as follow:

- Arrange the coupling with horizontal axis;
- Place the arrow marked on the casting at 12 o'clock position (rotating towards the top) the filler plug will be at an inclination in relation to vertical according to the angle inclined in the table below and fig.2.

Fill oil through one of the filler parts until the oil begin running out, paying attention that no air bubble is present. The coupling have never to be totally filled in order to avoid damages to the seals due to the inner pressure.

For the oil quantity required please refer to the table below.

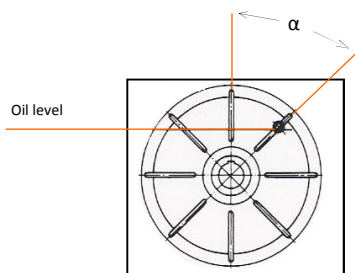

Recommended oils SAE 10 :

Agip OSO 32	Fina Hydran 32
BP Energol HLP 32	Mobil DTE 24
CHEVRON Hydraulic oil EP 32	SHELL Tellus 32
ESSO NUTO H 32	Total Azolla 32

For special conditions (temperature, ambient) please contacts your Turbostart distributor.

## OPERATION

The maximum operative temperature should not exceed 90°C.

In heavy duty working cycle, it is possible to exceed this value by using special seals.

High operating temperature can be caused by:

- insufficient oil filling
- high absorbed power, due to an extended overload
- long starting time and too frequent starts
- high ambient temperature
- insufficient air ventilation due to carter. Adequate ventilating apertures should be provided.

## MAINTENANCE

After few hours of operation, check the tightness of bolts and screws.

From time to time check that no oil leakages are present. Check the oil level once a month.

The oil should be changed every 4000 hours of operation or every 12 months.

Coupling size	Standard version			Version with device "R"		
	Angle α	litres	Kgs	Angle α	litres	Kgs
155 L / P	30°	0,770	0,670	70°	0,800	0,700
190 L / P	30°	1,300	1,130	70°	1,350	1,180
220 L / P	30°	2,100	1,830	60°	2,200	1,920
240N	30°	2,850	2,500	60°	3,000	2,620
275N	30°	4,370	3,800	60°	4,610	4,010
355 L / P	30°	5,570	4,850	60°	5,900	5,140
400 L / P	30°	8,700	7,400	70°	9,300	7,900
445 L / P	45°	10,300	9,000	70°	11,000	9,580
18 L	45°	15,520	13,500	80°	16,670	14,500
18 P	45°	15,670	13,630	80°	16,830	14,650
19S L	45°	20,000	17,400	80°	21,400	18,620
19S P	45°	20,150	17,530	80°	21,560	18,760
19 L	45°	23,570	20,510	80°	25,220	21,950
19 P	45°	23,720	20,640	80°	25,380	22,090
110S L	45°	45,000	39,300	58°	53,000	46,000
110 L	45°	55,200	48,030	80°	59,500	51,700

Coupling type	WEIGHTS WITHOUT OIL								
	P	P-R	L/MU	L-R/MU	L/E	L-R/E	L/S	L-R/S	CF
155	3,2	3,7	3,2	3,7	3,9	4,4	3,1	3,6	5,4
190	5	5,6	5	5,6	6,7	7,3	4,9	5,5	7,2
220	10	11	10	11	12,5	14,5	9,5	10,5	15,5
240N	11	12,5	11	12,5	14,5	16	10,5	12	19
275N	26	30	26	30	31	35	25	29	39
355	36,5	41,5	31,5	36,5	35,5	40,5	29,5	34,5	43,5
400	47	53	40	46	48	54	38	44	52
445	74,5	83,5	63	72	75	84	59	68	80,5
18	90	100	65	75	77	87	61	71	82,5
19S	100	113	91	104	113	126	87	100	122
19	140	155	100	115	119	134	93	108	128
110S	200	210	130	140	190	200	120	130	185
110	230	245	150	165	210	225	140	155	185

Weights are approximate and change according to the bore on the shaft and the flexible coupling.

NEW TURBOSTART Srl - 16 Prima Strada - San Felice - Segrate (Milano) Italy  
Tel. +39.02.70.30.81.20 Fax. +39.02.70.30.90.05  
[newturbostart@gmail.com](mailto:newturbostart@gmail.com) - [www.newturbostart.com](http://www.newturbostart.com)